

FT-151 LED

WARNING lamp

Technical specification:

- universal supply voltage: **12 – 36V DC**
- **Power consumption: 12V/24V**
Peak power consumption: 0.5A/0.25A
FT-151 LED / FT-151 LED DF: 1.5A/0.8A
- Peak/average rated power: **12V/24V – 6W/6W**
FT-151 LED / FT-151 LED DF: 12V/24V – 18W/20W
- special warning lamp approval compliant with **ECE Regulation 65 (TA1)**
- flash frequency: **f = 2Hz**
- ElectroMagnetic Compatibility – **EMC** certificate
- full waterproofness (**IP68**)
- shock-resistance – **IK**
- operating temperature: **-40°C to +55°C**
- reverse polarity protection system
- fixed polarisation: **GROUND** – white wire; **(+)** – black wire

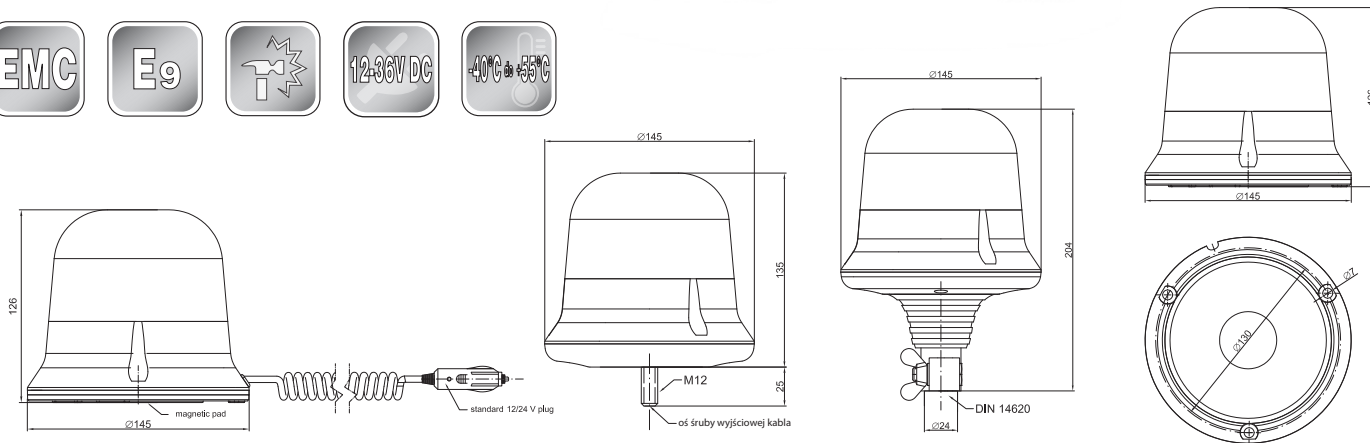

FT-151 3S LED	Yellow LED warning beacon, single flash , mounted on 3 screws. Cable's length 1.5 m.
FT-151 LED MAG M30	Yellow LED warning beacon mounted on a magnet, single flash . Additionally, the lamp is equipped with a spiral cable (unfolded – 3 m, in spiral – 0.6 m) and a standard 12/ 24V lighter plug.
FT-151 LED MAG M78	Yellow LED warning beacon mounted on a magnet, single flash . Additionally, the lamp is equipped with a spiral cable (unfolded – 7.8 m, in spiral – 1.2 m) and a standard 12/ 24V lighter plug.
FT-151 LED PI	Yellow LED warning beacon, single flash . The lamp appears in a stationary LED 12-36V version with a pipe-socket and electrical connector type PLUG-IN (DIN 14620).
FT-151 SC LED	Yellow LED warning beacon, single flash . The lamp appears in a stationary LED 12-36V version with a single bolt and a loom.
FT-151 3S DF LED	Yellow LED warning beacon, double flash , mounted on 3 screws, cable's length 1.5 m.
FT-151 DF LED MAG M30	Yellow LED warning beacon, double flash , portable version mounted on a magnet. The lamp is equipped with a spiral cable (unfolded – 3 m, in spiral – 0.6 m) and a standard 12/ 24V lighter plug.
FT-151 DF LED MAG M78	Yellow LED warning beacon, double flash , portable version mounted on a magnet. The lamp is equipped with a spiral cable (unfolded – 7.8 m, in spiral – 1.2 m) and a standard 12/ 24V lighter plug.
FT-151 DF LED PI	Yellow LED warning beacon, double flash . The lamp appears in a stationary LED 12-36V version with a pipe-socket and electrical connector type PLUG-IN (DIN 14620).
FT-151 SC DF LED	Yellow LED warning beacon, double flash . The lamp appears in a stationary LED 12-36V version with a single bolt and a loom.
FT-151 3S RO LED	Yellow LED warning beacon, rotation flash , mounted on 3 screws. Cable's length 1.5 m.
FT-151 RO LED MAG M30	Yellow LED warning beacon mounted on a magnet, rotation flash . Additionally, the lamp is equipped with a spiral cable (unfolded – 3 m, in spiral – 0.6 m) and a standard 12/ 24V lighter plug.
FT-151 RO LED MAG M78	Yellow LED warning beacon mounted on a magnet, rotation flash . Additionally, the lamp is equipped with a spiral cable (unfolded – 7.8 m, in spiral – 1.2 m) and a standard 12/ 24V lighter plug.
FT-151 RO LED PI	Yellow LED warning beacon, rotation flash . The lamp appears in a stationary LED 12-36V version with a pipe-socket and electrical connector type PLUG-IN (DIN 14620).
FT-151 SC RO LED	Yellow LED warning beacon, rotation flash . The lamp appears in a stationary LED 12-36V version with a single bolt and a loom.